

The use of IOT in Packaging System

Sasmita Mishra, Sonali Pradhan

College of Engineering Bhubaneswar, Biju Pattnaik University of Technology, Odisha, India

Abstract— Electronic commerce, or e-commerce, is the term for the online purchasing and selling of various goods and services. The internet boom and the comfort (and other services) it offers its users have made the word "e-Commerce" very well-known in recent times. With the aid of e-Commerce, numerous businesses have grown or established themselves. Numerous studies demonstrate an exponential rise in e-commerce sales and services, which will continue to soar in the years to come. The e-commerce industry has grown at a rate of 265%, from \$1.3 trillion in 2014 to \$4.9 trillion in 2021—a further increase. With such a large increase in e-commerce, people no longer prefer to purchase goods offline because doing so offers them more advantages. But regrettably, the business and its clients have to deal with a few issues. And over time, these problems have gotten worse, with serious problems relating to the flawed delivery system. In order to address these circumstances, we offer a solution that will prevent delivery-related issues from arising during delivery and put an end to them by guaranteeing that each customer receives the products as they are delivered directly from the dealer, free from any intervention. This study examines IoT insecure packaging solutions and the suggested methodology are covered in this report.

Index Terms: *Intelligent Packaging, Microcontroller, GPS, Sensors, Arduino.*

INTRODUCTION

The goal of the Intelligent Packaging System solution is to monitor the product's attributes as well as the environment inside and outside the box using electronic packaging to prevent package tampering during transit. The goal of the IPS project is to employ electronic packaging solutions to effectively trigger an alert upon package opening. Numerous sensors are used in a failsafe system to perform the monitoring. Single sensor-based systems have the drawback of not correlating data from various sources. The suggested approach uses a number of sensors, including GPS, to continuously monitor the physical characteristics of the package while it is in transit in order to determine whether the box has been opened or whether the temperature has increased (for pharmaceutical and temperature-sensitive products). After the manufacturer receives this alert, they are able to make the required corrections. The customer would have received a damaged product if there had been no alert and the delivery had gone as planned. Following delivery, the customer uses their phone to scan a QR code on the

IPS kit. This causes the customer's phone to receive an OTP, which they must enter to unlock the kit and reset their device. The delivery executive receives the IPS kit after it has been taken out of the box and put to use once more. The Internet of Things, or IoT, is more than just a hot industry trend and fascinating research topic. Intelligent packaging solutions assist in meeting the growing demand for efficient online purchase delivery management amidst the rapid growth of e-commerce.

BLOCK DIAGRAM DESCRIPTION

Numerous sensors are used by the IPS development kit, and

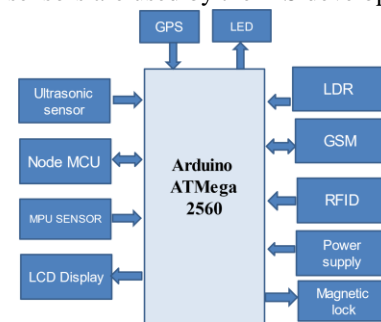

Figure 1: Block diagram

the Arduino Uno serves as the kit's brain. In addition to the DTH, LDR, GPS, MEMS, and IR sensors, we will also be using a number of modules, including a keyboard, LCD, GSM, and NODE MCU.

Fig 1 demonstrates the model's block diagram and the LCD display that is used to show each operation. Light Dependent Resistors, or LDRs for short, are sensors of light that are activated when the kit is opened without the OTP or when the equipment is not properly packed. A cheap inertia sensor called MEMS sensor is used to detect if the IPS box has been mishandled or if a thief has made an attempt. The IR sensor is an infrared sensor that can identify any intrusion in addition to detecting the presence of the package. The kit's live location is obtained via the GPS, and this

is sent to the user through a GSM module-assisted text message. The temperature and humidity within the kit are monitored by a DHT sensor, which is very useful when delivering or transporting any food or medications. All of these sensors are integrated by the core Arduino Uno, which also opens and closes the magnetic lock.

LITERATURE SURVEY

Ge Wang et al. [1] proposed a packaging system called Verifiable Smart Packaging with Passive RFID; in general, the courier packages, after someone orders them online, go through the packaging process and later is shipped to the customer; their primary job is to identify and track the items from the time it has been taken out for delivery till it is delivered but what happens between getting out for delivery and reaching to the customer is not accounted, An intruder can replace the items in the box. Noonewould even notice which is an eventual loss to the customer, So to avoid such malicious events verifying and testing of whether its safe inside, in other words, its authenticity is necessary, In this paper, a system is introduced using Passive RF tags, This is used to check the internal health of the package and to develop a non-destructible package and called it Echoscope. It only needs to determine whether the ID and signal features collected at a testing site match the record at the delivery site.

There are various ways of checking whether the inside of a package is intact, like Ultrasonic scanning, X-Rays. Still, these machines are neither cheaper nor mobile so what an Echoscope does is that it extracts backscattering signals from the package to check the status of the box. This first check is done once before the shipping phase and later before the package is delivered to the customer and reviews for any differences; if there are none, the package is delivered to the customer.

Advantage: This method is comparatively more straightforward because it uses an Echoscope which is low cost compared to other testing methods.

Disadvantage: The results are not as accurate as Ultrasonic scanning, X-Rays because the accuracy is compromised for cost.

Jiu Wen et al. [2] designed a Map-Matching Service system for better Trajectory of the couriers. Everyday there are thousands of online orders to be delivered to different locations. These generate tons of data about the courier trajectory. Still, it generally doesn't account for various factors. With a single approach, the data is sent through to the courier delivery workers and the customers about the estimated arrival of the package.

Map match plays an integral part in developing trajectories. The existing map matching either considers cars as a means of transportation or ignores it altogether, considering a single estimated time based on distance; therefore, the accuracy of such map matching trajectories is on the lower part and cannot be guaranteed. To achieve better accuracy and solve this problem, where a wider range of factors should be considered. The fundamental problem that map-matching faces is the "Fragmentation" problem because couriers have to deliver the packages to different locations. A car's positioning system is based on GPS, which is more reliable compared to the courier services that use a wi-fi locations system as their positioning system. Note everyone delivers in a Car. Most of them provide an electric bike or walk, which is slower than the car but can cut through narrow roads and avoid comparatively more traffic.

These factors create highly irregular trajectories that were previously ignored in existing map-matching circuits. Still, now after accounting for the factors mentioned above plus some more, the new map matching called Courier trajectory-based map-matching is more reliable and accurate with low time and space complexity with low latency.

Advantage: A map matching System is developed where various external factors like mode of transport are included in the map matching trajectory where we can do accurate delivery time estimates.

Disadvantage: Positioning information for developing Trajectory is generated using a wi-fi location system, which is not precise as Global Position System (GPS). Also, Tampering with packages is not checked during transit.

Advantage: The decision support system uses previous data and finds out the best route for delivering the package with the help of machine learning.

today's world, online ordering is a regular thing. Everyone orders through online applications since they get a lot of varieties, plus they don't have to get out of their home. An extensive supply chain of deliveries has negative impacts, like tampering with the package when the shipment is out for delivery. To prevent this, In this paper, the author has discussed how they can use weighing sensors, cameras, and alarms to avoid such unfortunate events. First, when the delivery is about to ship, the weight is checked using a pressure sensor later. If the weight of the package changes after a certain threshold, the alarm starts to buzz and intimate the company; a motion detection sensor is used to check if someone apart from the delivery worker gets near to the package. The motion detection is done using a PIR sensor, and it can also click pictures of the suspicious person, which we can later question. This system is a step towards improvement compared to other systems like lockers, and anti-theft briefcases, which are costlier and less efficient. The positioning system used in this is a wi-fi based positioning system instead of GPS. The assembly building is also more accessible than other systems. The control processor used in this is Arduino.

Advantage: An Anti-theft system is developed where the weight of the package is checked, and tampering is alerted using an alarm.

Disadvantage: Dependent on internet connectivity and the exact location of tampering is not recorded for future improvement

Skowron-Grabowska et al. [5] proposed using RFID technologies instead of other means like a barcode. Although it is cheaper, Barcode is also much slower than RFID and cannot process a large amount of data at once. Using RFID in Couriers has been a big revolution in the

past decade. RFID is 10x more efficient, and unlike barcodes where a person has to operate it for verification manually, RFID is entirely automated. It does not require any human work use it. The market in the current world is changing day by day. The courier firm needs more efficient and optimal solutions. In these ever-changing courier firms, where growth is necessary, this approach helps better manage and handle the data in courier firms. RFID performs various operations like tracking, verification, handling, and managing efficiently. RFID consists of RF tags (radio frequency tags), one at the receiver end and the other at the courier servicing end. It sends back and forth using these RF tags within a given range. The courier industry has started to adopt RFID and is exploring more options to compete and be more efficient in the Domain.

Advantage: RFID is 10x more efficient and is entirely automated, unlike barcodes where a person has to use it for verification manually.

Disadvantage: Tampering of packages is not checked during transit.

Wei Tu et al. [6] proposed the online crowdsourced delivery system for on-demand foods to connect from online to offline agencies. In recent days, online food delivery has become a growing business. Due to the increasing demand for online orders, the number of delivery staff required increases. This has become a significant problem for food-tech companies, especially start-ups. This paper focuses on solving such issues using public riders as part-time delivery agents. The riders can be compensated with small rewards for their service, attracting the crowd to provide their service. They try to use IoT and 3G/4G/5G to connect the public with the food joints or food companies. We will generate an online solution consisting of all the orders and an efficient delivery route for the crowd. A hybrid mathematical solution and machine learning are employed to assign food delivery tasks and generate the shortest delivery route in real-time. The crowd-sourced riders are shared among various food-delivering companies according to the area in which they operate. Although this method does not require any significant investment in hardware, it requires a lot of programming. Even if this method is implemented, its efficiency is dependent on the crowd. The food is also delivered not being secured, and hence it can tamper, which is terrible for the company's brand.

Advantage: Making use of public riders as part-time delivery agents.

Disadvantage: Requires a lot of programming, implementation and its efficiency is dependent on the crowd and cannot be controlled even with efficient programming

Tanja Nielset al. [7] Designed an effective way to reduce the complexity present in the delivery system and helps the common issue faced in metropolitan cities in our day-to-day life. Due to the drastic increase in the logistics

industries globally, there is high demand in the shipping of packages sent by courier, express and parcel service, which eventually affects the increase in the traffic density mainly in cities. The delivery tours run by the courier companies are done through diesel trucks, which causes an increase in traffic congestion and leads to air pollution.

The come up with an innovative solution, this paper proposes a solution for last-mile courier delivery of the allocated companies' cargo bikes and Electronic bikes. The procedure involves placing the reserved containers and truck trailer in a specific central region of the city, which acts as a mobile depot (pick up station) for delivering the packages to the nearby location. They analyze the conventional delivery data gathered and present an optimization scheme to determine a suitable place for the designated container. Further, have come up with a simulated route for the cargo and E-bikes. This approach is feasible in densely populated and congested cities. The prime aspect of this approach is also to reduce fuel consumption, which is facilitated by implementing specific E-bikes. The vehicle mileage given by truck is reduced from approximately 170 km to 43km. Even in this project, there is no safety provided by the author. Still, we can also pool our IPS concept here to securely protect a few of the expensive cargo and give an even more efficient way in the logistics industries.

Advantage: Diesel truck which in turn causes an increase in traffic congestion and lead to air pollution, can be avoided.

Disadvantage: It does not solve the problem of tampering.

Nivedita G et al. [8] proposed an Automation of parcel delivery collection using IOT to avoid answering a person at the door or collecting a door delivery. To deal with such problems, they came up with a solution to avoid the constraint of the availability of the customer at the time of product delivery using various IoT Applications. Their idea is to introduce a Smart Freight Box (SFB). The Smart freight box is a courier collecting box to be installed in our home like A/Cat place where the customer can access it both from inside and outside. It consists of a barcode sensor, weight sensor, loading cell, and doors on each side of the box for putting and collecting the parcel when the customer is out there. It will also contain a shifting belt where the package is placed initially. After verifying the package, we will shift it inside a ward where it is safe until the customer comes and accesses it. There are three phases in SFB. The first one is the pre-delivery phase, where the customer will place an order online on a website. After the confirmation of the order, the retailer will send the package details, including the Barcode and the weight of the package. The customer can store these details. The next phase is the delivery phase, where the delivery worker walks in

And places the delivery on the SFB. The SFB validates the parcel with two parameters. One is Barcode, and the other is its weight which is already given to the customer

beforehand. The weight sensor loading cells check the weight and shift it inside through a shifting belt, and the barcode sensor verifies the Barcode. In the last phase, which is the post-delivery phase, the delivery worker has to send an acknowledgment to the retailer that the parcel has been successfully placed after confirming with the customer.

Advantage: Automation in collecting the delivery parcel without human intervention and verifying package parameters like Barcode and weight.

Disadvantage: The package is accepted without checking for tampering and internal damages. If it exists, it will delay the return procedure.

Ajay Doltade et al. [9] proposed a basic overview of maintenance in the storage units to monitor the physical aspects of the storage centers used for storing agricultural-based products. These are considered staple food and are primarily consumed by most of the population. IoT and a few basic sensors monitor various physical parameters inside the storage unit. With the help of IoT, an alert is sent to the concerned personnel and hence constantly monitoring the storage conditions. This concept has an approach to monitoring grain storage or other edible products that might undergo spoilage if not subjected to suitable physical parameters. This paper focuses on improving the condition of such storage with the help of various sensors like DHT11, MQ2, MQ135, and PIR sensors based on the concept of IoT. This technique relies on wireless communication to the Blynk application and desktop system, making this process simple. The desktop system will provide information regarding captured data. We will interpret the data in terms of graphs and charts. The desktop system monitors the necessary parameter through the local area. In the absence of a manager or concerned personnel, this application will serve the purpose of maintenance.

Advantage: High degree of monitoring and tracking was used for storing agricultural-based products

Disadvantage: This technique is unfortunately limited to only agricultural-based products, and it does not detect any intrusion. This concept fails to protect the necessary product from theft or other such mishaps.

Ming et al. [10] With the prevalence of online to offline (O2O) commerce, the short-distance instant logistics service has become increasingly popular in China, which is a new logistics model that emerged recently and provided timely logistics for O2O local life service. Unlike traditional logistics, extra waiting time generates when an order's pick-up location arrival time is earlier than its pick-up ready time. Dynamic orders dispatch strategy is also a key factor affecting overall logistics service quality. However, existing industry practices are dispatching orders to the nearest couriers, and couriers themselves arrange logistics sequences. To improve general dispatch solutions, we present an innovative, dynamic order dispatch system (Smart DODS) and a personalized logistics sequence recommendation (PLSR) service to optimize courier logistics sequence in real-time. At last, we use the historical dispatch data set of SHBJ to evaluate our system performance. The experimental results demonstrate our system can effectively optimize logistics dispatch solutions intelligent Packaging Solutions for Safe Delivery

Advantage: historical dispatch data set is used to evaluate the system performance and improve efficiency.

Disadvantage: Tampering of packages is not checked during transit.

G Prabhakaran et al. [11] proposed storage monitoring for the food grain processing industry using an embedded system helpful in monitoring the food grain. Storage of these grains in the warehouse or the storage unit where faulty management leads to spoilage and lack of maintenance of these agricultural products. To overcome

this issue, they proposed a simple circuit as a storage unit that innovates a process in which the ultrasonic signals are echoed through the storage unit. The expected waves are received by the other end by the required receiver to monitor grain condition and quality constantly. An additional feature or one more important specification of this project is that this process helps anticipate the threats faced by the rodents, such as bugs and rats, which are prevalent threats faced in our day-to-day lives. One good reason to implement this process is the drawbacks of the old practice, whose setbacks can be infiltrated in this process. Some of them are delayed in the output signal, and signals obtained on the food condition are not prioritized. The working principle of this project involves a circuit combination of a microcontroller with echo pins for penetrating the sound waves through the grains present in the storage container. With the help of the microcontroller and the required echo pin mounted on the circuit board, the sound waves (ultrasonic waves) are transmitted on the top of the grain container, which is of conical shape; however, this prototype can be fabricated for any storage unit accordingly. The designated waves travel from the triggered echo pin and are reflected from hitting on the grains to the receiving end of the circuit. Now the received output signals are designated to the microcontroller, and the programmer processes the signals to convert CMOS logic into desirable input for the microcontroller. Then the processed data is displayed on the LCD accordingly. This method is helping the consumers, wholesalers, and mainly farmers in overcoming the significant drawbacks of the traditional grain storage method. This method also provides flexibility to look into the status and condition of grain. Anyway, the major setback caused due to rodents which leads to spoilage, is overcome systematically in this technique. This type of system overcomes grain storage's traditional approach drawbacks, gives efficiency and flexibility for accessing grain data, and minimizes grain wastage.

Advantages: This system overcomes traditional approach drawbacks of grain storage and gives efficiency and flexibility for accessing grain data, and minimizes grain wastage.

Disadvantage: The method of using Ultrasonic signals increases the cost of the project.

T. Wei et al. [12] To improve the ability of food packaging optimization and selection, combined with big data analysis method. Different food best packaging methods are selected, and an extensive data classification technology for various food packaging methods is proposed based on fuzzy directivity classification. Big data parametric model which reflects the best packaging characteristics of different foods is extracted, and the extracted packaging parameters are matched by adaptive fuzzy matching. Then, the directional clustering method is used to classify and identify big data, combined with the food packaging. **Advantage:** This method is used to select the best packaging methods for different foods. It has better intelligence, improves the ability to classify and

recognize food packaging, and promotes the intellectual development of food packaging. It has good application value in practice.

Disadvantage: The traditional classification methods for different food packaging feature data's associated data are mainly fuzzy C-means clustering and K-means clustering. The above method has some problems, such as too much computation overhead and poor accuracy in classifying large-scale different food packaging feature data.

Stephane Evoy. Et Al [13] Proposed an Intelligent Packaging Systems: Using sensors and nanosensors to monitor food quality and safety. This type of packaging analyzes the system, processes information, and presents it without generally exerting any action on the food. In this intelligent packaging System, they have used RFID signals or bar codes to keep track of the items. This paper also uses biosensors which help to control the environment in the food package

Advantage: The data systems used in this system allow control of the environment by using biosensors

Disadvantage: The cost of the sensors and actuators is relatively high, and also the maintenance is expensive

P. Suppakul, J. Miltz Et Al [14] Active Packaging Technologies with an Emphasis on Antimicrobial Packaging and its Applications: In this method, we used (LDPE) films coated with a mixture of polyamide resin in i-propanol/n-propanol and a bacteriocin solution provided A activity against *Micrococcus flavus*. The migration of bacteriocins reached equilibrium within 3d, but the level attained was too low to affect several bacterial strains spread on an agar plate. When the films were in contact with a phosphate buffer solution containing strains of *M. flavus* and *L. monocytogenes*, a marked inhibition of microbial growth of both strains was observed.

Benefit: The best way to ensure food safety and prolong its safety A disadvantage is that they are more costly than their main competitors. Therefore, the commercialization of such films might become feasible, but only for high-end food items. Applying chemical products to food is not safe.

Miltz Joseph et al. [15] Joseph Miltz, Principles and Applications of Intelligent Packaging This study defines "intelligent packaging" in terms of a suggested model of packaging functions based on the development of food packaging. Additionally, a framework explaining the structure of the intelligent packaging system and giving the concept a more precise meaning is being developed. Recent advancements in intelligent package devices—such as radio, barcode labels, and biosensors, time-temperature indicators, gas indicators, and tags with frequency identification.

Advantage: This system makes use of the latest advances in intelligent package devices, including barcode labels, radio frequency identification tags, time-temperature indicators, gas indicators, and biosensors **Disadvantage:** This system fails to address economics, legislation, and consumer privacy.

CONCLUSION

We are utilizing an electronic packaging solution known as the IPS development kit in the design and implementation of the non-destructive package testing and verification solution. The kit will be placed inside the package with enough room for it to function properly. The kit will travel to its destination inside the box, which we will take out after delivery. The kit will sound an alarm if there is any tampering or intrusion during the delivery process. By doing this, we are preserving both the reputation of the businesses using our system and the integrity of the product. Our goal is to guarantee customer satisfaction by providing them with the desired outcome without any issues.

REFERENCE

- [1] G.Wangetal., "VerifiableSmartPackagingwithPassiveRFID," in IEEE Transactions on Mobile Computing, vol. 18, no. 5, pp.1217-1230, 1 May 2019.
- [2] J.WenandY.Sun,"AMap-MatchingServiceDesignedforCourierTrajectories," 2017 IEEE International Conference on WebServices (ICWS), Honolulu, HI, 2017.
- [3] Turban E, Aronson JE, Liang TP. 2007. DecisionSupport Systemsand Intelligent Systems.Seventh Edition. Prentice Hall of India.New Delhi & Marimin, Maghfiroh N. 2010. Aplikasi TeknikPengambilan Keputusan dalam Manajemen Rantai Pasok. IPBPress. Bogor.
- [4] JoeBianco,JohnGraft,JohnSimonaitisTeam9TA:ZipengWang2/22/2018Package Anti-Theft System.
- [5] B. Skowron-Grabowska and T. Szczepanik, "Application ofRFIDtechnologiesinlogisticscentrestoimprovingoperationsofcourierfirms," 2017 IEEE International Conference on RFID Technology&Application(RFID-TA),2017,pp.140-145,doi:10.1109/RFID-TA.2017.8098895.
- [6] W. Tu, T.Zhao,B. Zhou,J.Jiang, J.XiaandQ. Li, "OCD:OnlineCrowd sourced Delivery for On-Demand Food," in IEEE Internetof Things Journal, Aug. 2020.
- [7] Niels, Tanja &Hof, Moritz &Bogenberger, Klaus. (2018). Designand Operation ofan Urban Electric Courier Cargo Bike System.
- [8] Nivedhitha.G,T.Sujithra&AksheyaSuresh,Bhavadharani(2017)Automation of parcel deliverycollection using IOT -Smart freightbox(IJCIET).
- [9] Ajay Doltade, Ankita Kadam, Sayali Honmore, Sanjeev Wagh,"Intelligent Grain StorageManagement System based onIoT",International Journal of Science and Research(IJSR), Volume 8Issue 3, March 2019, 1749 – 1752
- [10] Y. -M. Wei, X. -Q. Qiao, J. -L. Chen, Y.-Z. Feng and C. Wang,"SmartDODS:ASmartDynamicOrderDispatchSystemforShort-Distance Instant Logistics Service," 2017 IEEE InternationalConference on Web Services (ICWS), 2017, pp. 818-821, doi:10.1109/ICWS.2017.98.G. Prabhakaran, C. Kiruthikalakshimi,S. Mithila, C.Subhananthi, T. Subramini, 2018, Storage Monitoring for FOODGRAIN Processing Industry using Embedded System,International Journalof engineering research &technology(IJERT) ETEDM– 2018 (Volume 6 – Issue 04).
- [11] T.WeinandS.Xiangbo,"SelectionofOptimalPackagingMethodsfor Different Food Based on Big Data Analysis," 2020 IEEEInternational Conference on Power, Intelligent Computing andSystems (ICPICS), 2020, pp. 558-561, doi:10.1109/ICPICS50287.2020.9202379.
- [12] Guillermo Fuertes, Ismael Soto, Raúl Carrasco, Manuel Vargas,Jorge Sabatin, Carolina Lagos, "Intelligent Packaging Systems:Sensors and Nanosensors to Monitor Food Quality and Safety",JournalofSensors, vol. 2016, ArticleID4046061, 8 pages, 2016.<https://doi.org/10.1155/2016/4046061>
- [13] Suppakul, P., Miltz, J., Sonneveld, K.andBigger, S.W., 2003.Activepackagingtechnologieswithanemphasisonantimicrobialpackaging and its applications. Journal of food science,

68(2),pp.408-420.

- [14] Yam,K.L.,Takhistov,P.T.andMiltz,J.,2005.Intelligentpackaging: concepts and applications.Journal of foodscience, 70(1),pp.R1-R10. class=ReactionStaticEmojiv:shapes="_x0000_i1025"

>